

LEA-5H, LEA-5S, LEA-5A u-blox 5 GPS/GALILEO Modules

Data Sheet

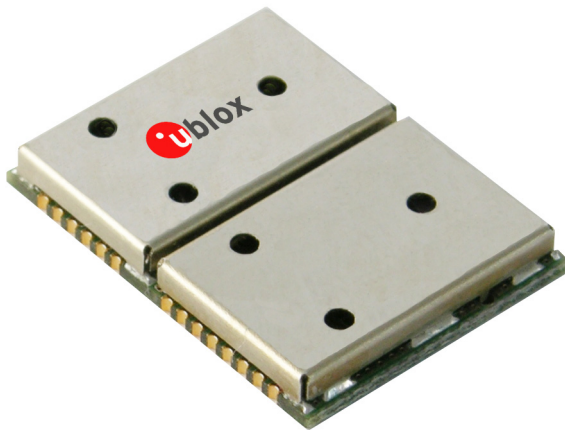

Abstract

Technical data sheet describing the cost effective, high-performance u-blox 5 based LEA 5 series of GPS/GALILEO modules.

Features include A-GPS support, low power consumption, -160 dBm high sensitivity and an innovative jamming-resistant RF architecture. The compact 17.0 x 22.4 mm form factor of the highly successful LEA-4 series is maintained, enabling easy migration. The LEA 5 series supports passive and active antennas.



Title	LEA-5H, LEA-5S, LEA-5A		
Subtitle	u-blox 5 GPS/GALILEO Modules		
Doc Type	Data Sheet	Preliminary	
Doc Id	GPS.G5-MS5-07026-P2		
Revision Index	Date	Name	Status / Comments
P1	17/07/2007	TG	Preliminary
P2	8/08/2007	TG	

This document and the use of any information contained therein, is subject to the acceptance of the u-blox terms and conditions. They can be downloaded from www.u-blox.com.

u-blox reserves all rights to this document and the information contained herein. Reproduction, use or disclosure to third parties without express permission is strictly prohibited. Copyright © 2007, u-blox AG.

For most recent documents, please visit www.u-blox.com

Data Sheet Revisions	Identification of applicable hardware	Comments
-	All data codes	

	Products marked with this lead-free symbol on the product label comply with the "Directive 2002/95/EC of the European Parliament and the Council on the Restriction of Use of certain Hazardous Substances in Electrical and Electronic Equipment" (RoHS).
	This is an Electrostatic Sensitive Device (ESD). Observe precautions for handling.

1 Functional Description

1.1 Overview

The LEA-5 series of GPS/GALILEO modules introduces a new standard in GNSS (Global Navigation Satellite System) receiver technology. Based on the unequalled 50 channel u-blox 5 technology, these modules provide exceptional performance in a compact form factor and at an economical price. A 32 channel acquisition engine with over 1 million effective correlators is capable of massive parallel searches across the time/frequency space. This enables a Time To First Fix (TTFF) of less than 1 sec while long correlation/dwell times make possible an acquisition and tracking sensitivity of -160dBm. An optional feature is KickStart: an acquisition accelerator for weak signals. Once acquired, satellites are passed on to a dedicated tracking engine. This arrangement allows the GPS/GALILEO engine to simultaneously track up to 16 satellites while searching for new ones.

u-blox 5's advanced jamming suppression mechanism and innovative RF architecture provides a high level of immunity to jamming, ensuring maximum GPS/GALILEO performance.

The LEA-5 series maintains the compact 17.0 x 22.4 mm form factor of the highly successful LEA-4 modules. The modules have been designed with backwards compatibility in mind, enabling ease of upgrade and reducing engineering and design costs. LEA-5 modules feature a USB port for faster data transmission and more flexibility. The optional FLASH EPROM provides capacity to store user-specific configuration settings and allows for future updates. This functionality will for instance enable processing GALILEO L1 signals when this system comes into operation.

The LEA-5 series are not designed for life saving or supporting devices or for aviation and should not be used in products that could in any way negatively impact the security or health of the user or third parties or that could cause damage to goods.

1.2 Highlights and Features

Highlights

- **Time To First Fix (TTFF): < 1 sec**
- **Acquisition and tracking sensitivity: -160dBm**
- **Receives GPS and GALILEO signals**
- **A-GPS: Supports u-blox AssistNow® Online and Offline**
- **High immunity to jamming**
- **UART serial port, USB, DDC (I2C® compatible)**

Features

	50 channel engine	KickStart	SuperSense	Thickness	Voltage Range	FW Update / FLASH	UART	USB	SPI	DDC	AssistNow Online	AssistNow Offline	Timing	Raw Data	CFG Pin	DR	Reset Input	Antenna Supply	Antenna Supervisor
LEA-5H	✓	✓	✓	3.0mm	2.7-3.6V	✓	1	1		✓	✓	✓					✓	✓	✓
LEA-5S	✓	✓	✓	3.0mm	2.7-3.6V		1	1		✓	✓	✓			1		✓	✓	✓
LEA-5A	✓		✓	3.0mm	2.7-3.6V		1	1		✓	✓	✓			1		✓	✓	✓

Table 1: Features of the LEA-5 Series of Modules

1.3 Block Diagram

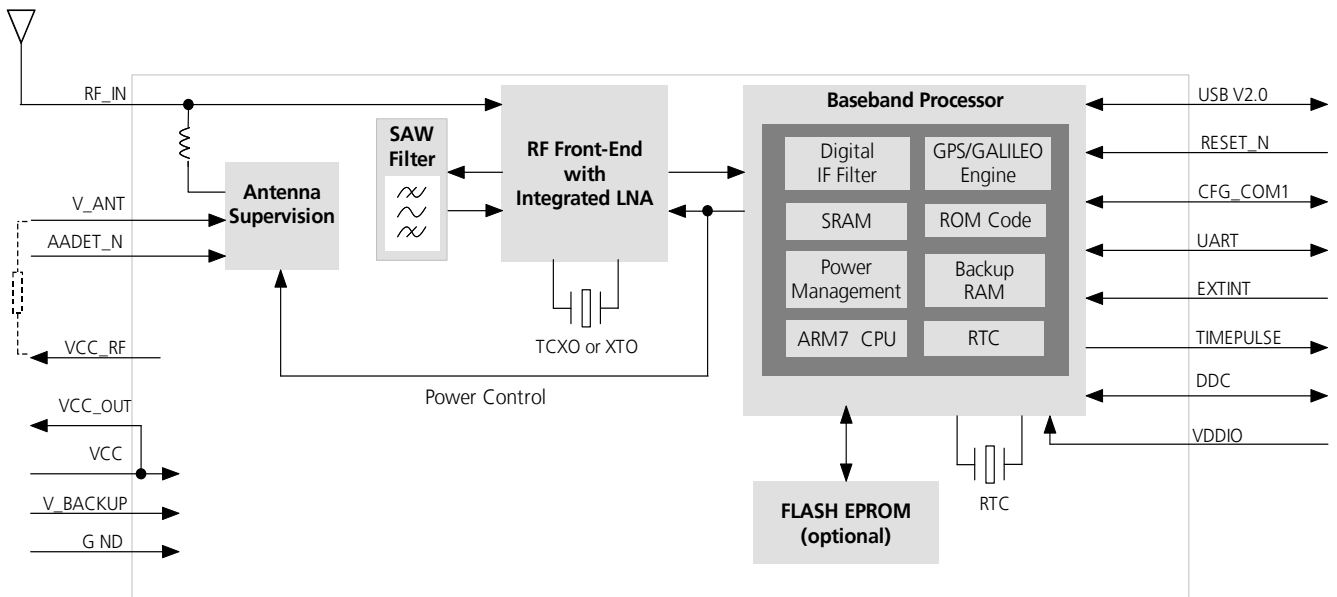

Figure 1: Hardware Block Schematic

1.4 Assisted GPS (A-GPS)

Supply of aiding information like ephemeris, almanac, rough last position and time and satellite status and an optional time synchronization signal will reduce time to first fix significantly and improve the acquisition sensitivity. All LEA-5 modules support the u-blox AssistNow Online® and AssistNow Offline® A-GPS services.

1.5 GALILEO

The u-blox 5 is a GNSS chip, that receives and tracks GPS and GALILEO signals simultaneously, enhancing accuracy and coverage. When GALILEO-L1 signals become available, u-blox 5 receivers equipped with FLASH memory will be capable of receiving and processing them via a simple upgrade. The ability to receive and track GALILEO satellite signals will result in higher coverage, improved reliability and better accuracy.

1.6 Protocols

The LEA-5 series offers 1 USB V2.0 interface and 1 UART serial interface both supporting different protocols.

Protocol	Type
NMEA	Input/output, ASCII, 0183, 2.3 (compatible to 3.0)
UBX	Input/output, binary, u-blox proprietary

Table 2: Available Protocols

For specification of the various protocols see the *u-blox 5 Protocol Specification* [2].

1.7 Antenna

LEA-5 modules are designed for use with passive and active antennas. An optional antenna supervisor is available with the LEA-5H, LEA-5S and LEA-5A. In the default operation mode the antenna supervisor is activated and enables the receiver to detect short circuits to the active antenna by checking the bias voltage level and can shut down the voltage bias immediately. A series resistor is needed in front of the **V_ANT** input. UBX and NMEA messages are provided to report the condition of the antenna supply. Open circuit detection can also be supported with an additional external circuit. For details, please refer to the *LEA-5 Hardware Integration Manual* [1].

Parameter	Specification	
Antenna Type	Passive and active antenna	
Active Antenna Recommendations	Minimum gain	15 - 20 dB (to compensate signal loss in RF cable)
	Maximum noise figure	1.5 dB
	Maximum gain	50 dB

Table 3: Antenna Specifications for all LEA-5 Modules

Parameter	Specification	
Antenna Supply	Using VCC_RF or external voltage source	
Antenna Supervisor	Short circuit detection	Built-in
	Open circuit detection	Enabled with external circuit

Table 4: Antenna Supervisor Specifications for LEA-5H, LEA-5S and LEA-5A

1.8 Configuration

1.8.1 Boot-Time CFG_COM1 Configuration

The LEA-5A and LEA-5S provide a **CFG_COM1** pin for boot-time configuration. It becomes effective immediately after start-up. Once the module has started, the configuration settings may be modified with UBX configuration messages. The Baudrate can be changed using the **CFG-PRM** message and the messages can be changed using **CFG-MSG**. The modified settings remain effective until power-down or reset. If these settings have been stored in battery-backup RAM, then the modified configuration will be retained, as long as the backup battery supply is not interrupted.

CFG_COM1	Baudrate (Kbaud)	Messages
0	4.8	GSV ¹ , RMC, GSA, GGA, GLL, TXT
1	9.6	GSV, RMC, GSA, GGA, GLL, VTG, TXT

Table 5: Supported CFG_COM1 settings (default settings in bold text)

1.8.2 Configuration (LEA-5H)

With the LEA-5H, configuration settings modified with UBX configuration messages can be saved to the FLASH memory. In this case the modified settings remain effective even after power-down and don't require backup battery supply.

For more information see the *LEA-5 Hardware Integration Manual* [1].

¹ every fifth fix

2 GPS Performance

Parameter	Specification	
Receiver Type	50 Channels GPS L1 frequency, C/A Code GALILEO Open Service L1 frequency	
Time-To-First-Fix	Sky View Module	Open Sky ² Indoor ³ ALL LEA-5H/LEA-5S LEA-5A
	Cold Start (Autonomous)	29 s
	Hot Start (Autonomous)	<1 s 10 s TBD.
	Aided Starts	<1 s 10 s 10 s
	Reacquisition	<1 s 10 s TBD.
Sensitivity	Tracking & Navigation	-160 dBm
	Acquisition & Reacquisition	-160 dBm
	Cold Start (Autonomous)	-145 dBm
Horizontal Position Accuracy ⁴	Autonomous	< 2.5 m
	SBAS	< 2.0 m
Accuracy of Timepulse Signal	RMS	50 ns
Max Navigation Update Rate		4 Hz
Dynamics		≤ 4 g
Operational Limits	Velocity	515 m/s (1000 knots)

Table 6: LEA-5 GPS Performance

² All satellites at -130 dB

³ All satellites at -155 dBm

⁴ 50%, 24 hours static, -130dBm

3 Mechanical Specifications

Parameter	Specification	
A	22.4 +0.06/-0.01mm	[882 +24/-4mil]
B	17.0 ±0.1mm	[669 ±4mil]
C	3.0 ±0.3mm	[118 ±12mil]
D	2.55 +0.3/-0.01mm	[100 +18/-4mil]
E	1.1 ±0.1mm	[43 ±4mil]
F	3.80 ±0.1mm	[150 ±4mil]
G	1.10 ±0.1mm	[75 ±4mil]
H	2.85 +0.3/-0.01mm	[112 +18/-4mil]
Weight	2.1 g	

Table 7: Dimensions

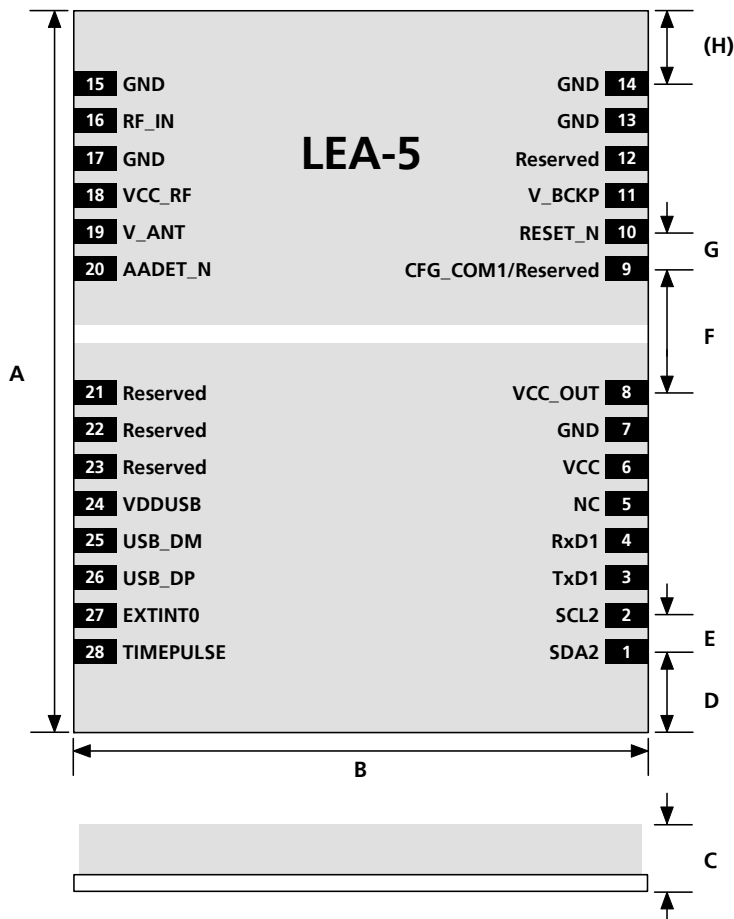

Figure 2: Dimensions

! **Note** For information regarding the Paste Mask and Footprint see the *LEA-5 Hardware Integration Manual* [1].

3.1 Pin Assignment

No	Module	Name	I/O	Description
1	All	SDA2	I/O	DDC Data
2	All	SCL2	I/O	DDC Clock
3	All	TxD1	O	Serial Port 1
4	All	RxD1	I	(do not leave open)
5	All	NC		Not Connected
6	All	VCC	I	Supply voltage
7	All	GND	I	Ground
8	All	VCC_OUT	O	Output voltage
9	LEA-5A, LEA-5S	CFG_COM1	I	Configuration Pin
	LEA-5H	Reserved	I	
10	All	RESET_N	I	
11	All	V_BCKP	I	Backup voltage supply
12	All	Reserved	I	
13	All	GND	I	Ground
14	All	GND	I	Ground
15	All	GND	I	Ground
16	All	RF_IN	I	GPS signal input
17	All	GND	I	Ground
18	All	VCC_RF	O	Output Voltage RF sect.
19	All	V_ANT	I	Antenna Bias voltage
20	All	AADET_N	I	Active Antenna Detect
21	All	Reserved		
22	All	Reserved		
23	All	Reserved		
24	All	VDDUSB	I	USB Supply
25	All	USB_DM	I/O	USB Data
26	All	USB_DP	I/O	USB Data
27	All	EXTINT0	I	External Interrupt Pin
28	All	TIMEPULSE	O	Time pulse (1PPS)

Table 8: Pinout

! Note Pins designated Reserved should only be used with caution. For more information about Pinouts see the *LEA-5 Hardware Integration Manual* [1].

4 Electrical Specifications

4.1 Absolute Maximum Ratings

Parameter	Symbol	Min	Max	Units
Power supply voltage (VCC)	Vcc	-0.5	3.6	V
Backup battery voltage (V_BCKP)	Vbckp	-0.5	4.8	V
Input pin voltage	Vin	-0.5	Vcc +0.5	V
	Vin_usb	-0.5	Vddusb +0.5	V
VCC_RF output current	Iccrf		100	mA
Antenna bias voltage	Vant		6	V
Antenna bias current ⁵	Iant		100	mA
Storage temperature	Tstg	-40	85	°C

Table 9: Absolute Maximum Ratings

- ! Warning** Stressing the device beyond the “Absolute Maximum Ratings” may cause permanent damage. These are stress ratings only. The product is not protected against overvoltage or reversed voltages. If necessary, voltage spikes exceeding the power supply voltage specification, given in table above, must be limited to values within the specified boundaries by using appropriate protection diodes.

⁵ Applied via V_ANT

4.2 Operating Conditions

Parameter ⁶	Symbol	Min	Typ	Max	Units	Condition
Power supply voltage (VCC)	Vcc	2.7		3.6	V	
Sustained supply current ⁷	Icc		40		mA	Vcc = 3.0 V
Peak supply current ⁸	Iccp		TBD		mA	Vcc = 3.6 V
Sleep mode current	Iccs		TBD		µA	Vcc = 3.0 V
Backup battery voltage	Vbckp	1.3		4.8	V	
Backup battery current	Ibckp				µA	Vbat = 3.3V
Input pin voltage range	Vin			Vcc +0.5	V	
Input pin low voltage	Vin_low_1			0.2x Vcc	V	
Input pin high voltage	Vin_high_1	0.7x Vcc			V	
Input pin low voltage for EXTINT0 and RxD1	Vin_low_2			0.22	V	
Input pin high voltage for EXTINT0 and RxD1	Vin_high_2	0.91			V	
Output pin voltage range	Vout				V	
Output pin low voltage	Vout_low			0.4	V	Iout = 4 mA
Output pin high voltage	Vout_high	Vcc – 0.4			V	Iout = -4 mA
VDDUSB (Pin 24) for USB operation	Vddusb1	3.0 ⁹		3.6	V	
USB_DM, USB_DP	VinU	Compatible with USB with 27 Ohms series resistance				
Antenna gain	Gant			30	dB	
V_ANT antenna bias voltage	Vant	2.7		5.5	V	I _{ANT} < -50 mA
Antenna bias voltage drop	Vant_drop		0.1			Iccrf=50mA
VCC_RF voltage	Vccrf				V	
VCC_RF output current	Iccrf			50	mA	
Operating temperature	Topr	-40		85	°C	

Table 10: Operating Conditions

! **Note** Operation beyond the "Operating Conditions" is not recommended and extended exposure beyond the "Operating Conditions" may affect device reliability.

⁶ All specification are at an ambient temperature of 25°C.

⁷ Average current drawn during Continuous Tracking Mode with 1 Hz update rate, using 9 channels for tracking and navigation and 3 channels for searching satellites (= acquisition). Use this figure to determine required battery capacity.

⁸ Peak current drawn during initial acquisition phase. Use this figure to dimension maximum current capability of power supply.

⁹ If USB not used connect to GND

5 Environmental Specifications

Detailed description of the test series:

Test		Standard
Visual inspection		IPC-A-610 "Acceptability of electronic assemblies" I.T.R.I. Publication No. 700 IPC-SM-840B Class 2.
Thermal shock	-40°C...+125°C, 100 cycles	IEC 68-2-14
Function at various temperatures	-40°C/2 hours; RT/2 hours; +85°C/2 hours; function tests at stable temperature	IEC 68-2-1 and IEC 68-2-2
Lifespan test	+85°C/1000 hours, in function	IEC 68-2-2
Damp heat, cyclic	+25°C...+55°C; >90% Rh	IEC 68-2-30
Vibration	10-500 Hz; 2 hours/axis; 5g	IEC 68-2-6
Shock	30g/11ms (halfsine); 3 Shock/axis; no function	IEC 68-2-27
Metallographic investigations		IPC-QE-650

Table 11: Environmental Specification

! **Note** This specification is preliminary and subject to confirmation.

6 Design-In

In order to obtain the necessary information to conduct a proper design-in, u-blox strongly recommends consulting the LEA-5 Hardware Integration Manual [1].

7 Default Settings

Interface	Settings
Serial Port 1 Output	9600 Baud, 8 bits, no parity bit, 1 stop bit Configured to transmit both NMEA and UBX protocols, but only following NMEA and no UBX messages have been activated at start-up: GGA, GLL, GSA, GSV, RMC, VTG, TXT
USB Output	Configured to transmit both NMEA and UBX protocols, but only following NMEA and no UBX messages have been activated at start-up: GGA, GLL, GSA, GSV, RMC, VTG, TXT USB Power Mode: Bus-Powered
Serial Port 1 Input	9600 Baud, 8 bits, no parity bit, 1 stop bit Automatically accepts following protocols without need of explicit configuration: UBX, NMEA The GPS receiver supports interleaved UBX and NMEA messages.
USB Input	Automatically accepts following protocols without need of explicit configuration: UBX, NMEA The GPS receiver supports interleaved UBX and NMEA messages. USB Power Mode: Bus-Powered
Time pulse	1 pulse per second, synchronized at rising edge, pulse length 100ms

Table 12: Available Protocols.

Please refer to the *LEA-5 Hardware Integration Manual* [1] for information about further settings.

8 Ordering Information

Ordering No.	Product
LEA-5A-0	LEA-5A GPS/GALILEO Module, Tape on reel, 250 pieces per reel
LEA-5H-0	LEA-5H GPS/GALILEO Module, Tape on reel, 250 pieces per reel
LEA-5S-0	LEA-5S GPS/GALILEO Module, Tape on reel, 250 pieces per reel
EVK-5H-0	u-blox 5 Evaluation Kit

Table 13: Ordering Information

Related Documents

- [1] LEA-5 Hardware Integration Manual, Docu. No GPS.G5-MS5-07005
- [2] u-blox 5 Protocol Specification, Docu. No GPS.G5-X-07003
- [3] u-blox 5 Receiver Description, Docu. No GPS.G5-X-07018

All these documents are available on our homepage (<http://www.u-blox.com>).

Contact

For further info, please contact us:

Headquarters

u-blox AG

Zuercherstrasse 68
CH-8800 Thalwil
Switzerland

Phone: +41 44 722 74 44
Fax: +41 44 722 74 47
E-mail: info@u-blox.com

www.u-blox.com

Sales Offices

North, Central and South America

u-blox America, Inc.

1902 Campus Commons Drive
Suite 310
Reston, VA 20191
USA

Phone: +1 (703) 483 3180
Fax: +1 (703) 483 3179
E-mail: info_us@u-blox.com

Regional Office West Coast:

8600 Lemon Ave #1
La Mesa, CA 91941
USA

Phone: +1 (619) 741 3011
Fax: +1 (619) 741 4334
E-mail: info_us@u-blox.com

Technical Support:

Phone: +1 (703) 483 3185
E-mail: support_us@u-blox.com

Europe, Middle East, Africa

u-blox AG

Zuercherstrasse 68
CH-8800 Thalwil
Switzerland

Phone: +41 44 722 74 44
Fax: +41 44 722 74 47
E-mail: info@u-blox.com

Technical Support:

Phone: +41 44 722 74 74
E-mail: support@u-blox.com

Asia, Australia, Pacific

u-blox Singapore Pte. Ltd.

435 Orchard Road
#19-02, Wisma Atria,
Singapore 238877

Phone: +65 6734 3811
Fax: +65 6736 1533
E-mail: info_ap@u-blox.com
Support: support_ap@u-blox.com

Regional Office China:

Room 716-718
No. 65 Fuxing Road
Beijing, 100036, China

Phone: +86 10 68 133 545
Fax: +86 10 68 217 890
E-mail: info_cn@u-blox.com
Support: support_cn@u-blox.com

Regional Office Korea:

Room 501, Gyeong Hui Building 109-18,
Samseong-Dong,
GangNam-Gu,
Seoul, Korea 135-090

Phone: +82 2 542 0861
Fax: +82 2 542 0862
E-mail: info_kr@u-blox.com
Support: +82 31 383 2584
support_kr@u-blox.com

Regional Office Taiwan:

Room 305
3F, #181, ZouTze Street
Neihu Dis.
Taipei, Taiwan

Phone: +886 2 2657 1090
Fax: +886 2 2657 1097
E-mail: info_tw@u-blox.com
Support: support_tw@u-blox.com